

CONTENDER

STEP UP TO THE PLATE



COMMERCIAL ICE MAKER

IMF038 | IMF037 | IMF040 | IMF039

01

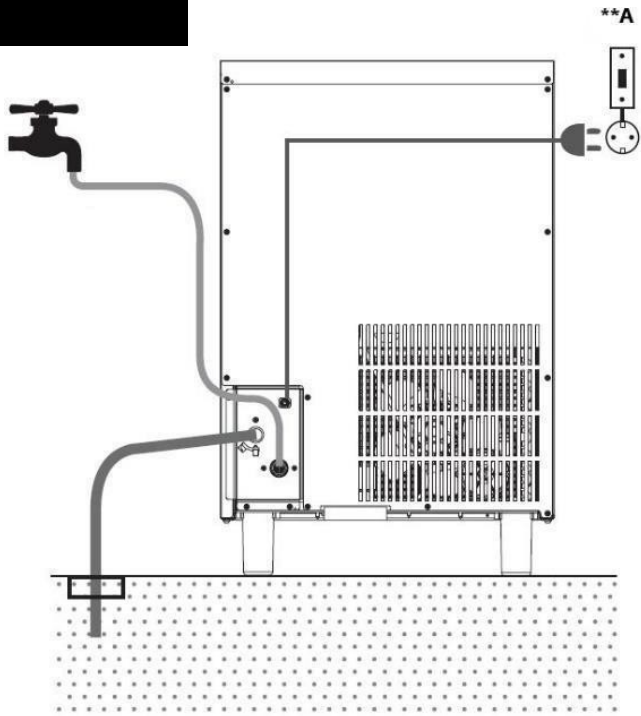

02

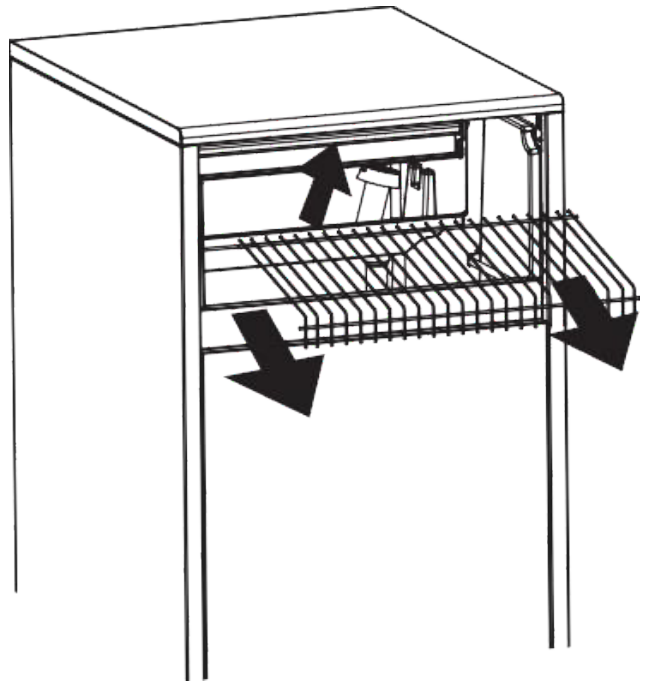

03

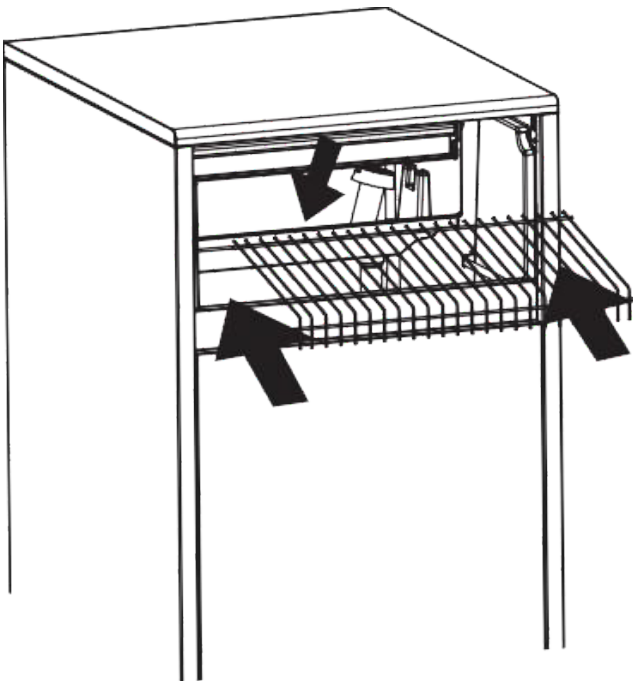

MAKE SURE THE ICE SLIDE GRATE IS POSITIONED CORRECTLY IN THE TANK AS PICTURED ABOVE.

04

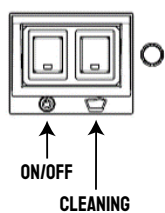
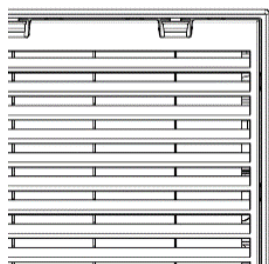

05

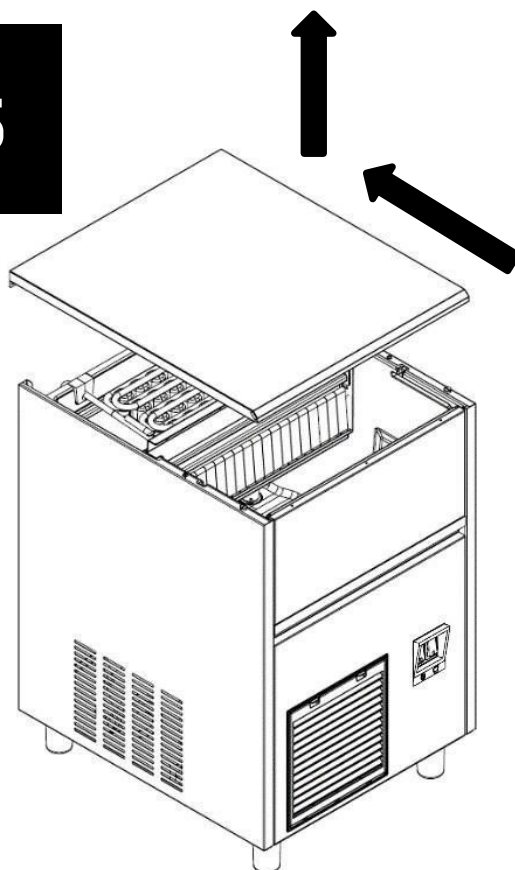

06

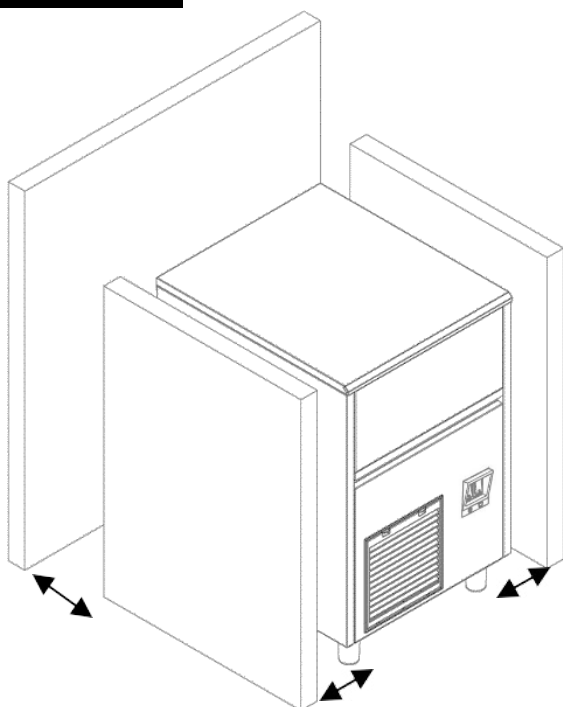

07

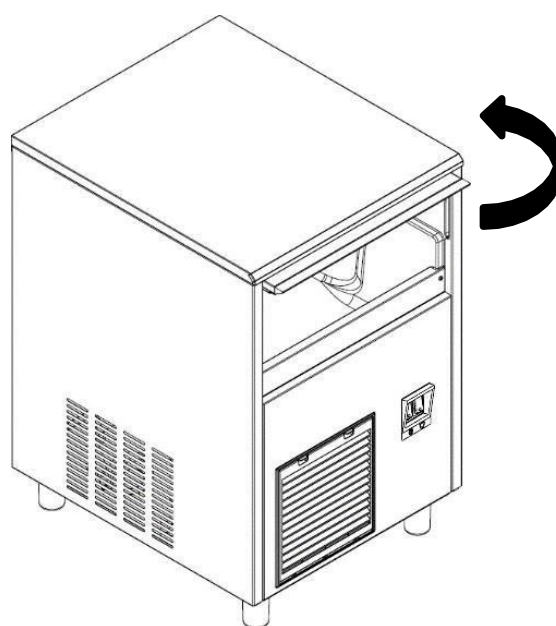

LOCATION

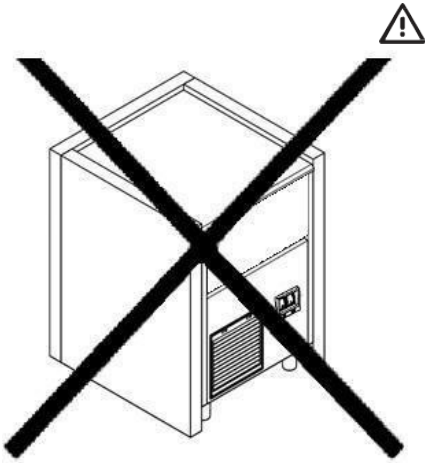

IN CASE THE UNIT IS LOCATED IN AN AREA WITH NO SIDE VENTILATION, ICE MAKER DOES NOT WORK PROPERLY. LEAVING ENOUGH ROOM AROUND THE UNIT WILL ALLOW THE UNIT WORK PROPERLY. NORMAL ICE-PRODUCTION CAPACITY IS DIRECTLY RELEVANT WITH THE CONDENSER AIR DELTA TEMPERATURE, WATER TEMPERATURE, STATES OF THE CONDENSER AIR CHANNEL AND AGE OF THE MACHINE.

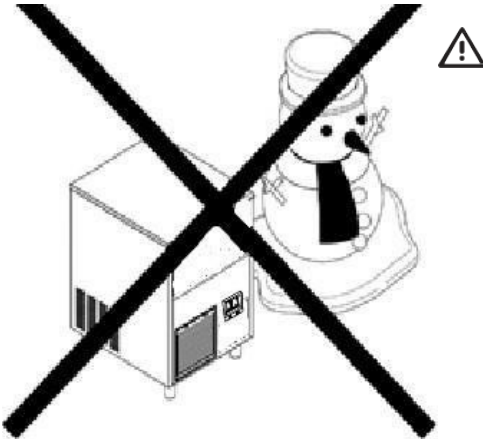

THE ICE MACHINE MUST BE LOCATED INSIDE TEMPERATURE CONTROLLED ROOM. RUNNING THE ICE MACHINE OUTDOORS OR IN AN AREA THAT THE TEMPERATURE CAN GO OUTSIDE OF THE WORKING LIMITS MAY HARM THE MACHINE, AND YOUR WARRANTY MAY BECOME VOID. ICE MACHINES ARE DESIGNED AND BUILT WITH THE HIGHEST RESPECT FOR SECURITY.

NOTE:

THIS USER'S MANUAL HAS BEEN ISSUED FOR SEVERAL MODELS. SOME FEATURES MENTIONED IN THIS MANUAL (INDICATED BY *) MAY NOT BE AVAILABLE ON YOUR PRODUCT.

“READ THE INSTRUCTIONS BEFORE ASSEMBLING OR USING THIS ICE MAKER.” THIS PRODUCT HAS BEEN MANUFACTURED IN ENVIRONMENT-FRIENDLY MODERN FACILITIES WITHOUT HARMING THE ENVIRONMENT.

CONTENTS

CHAPTER 01	SAFETY WARNINGS	6
CHAPTER 02	GENERAL OUTLOOK AND TECHNICAL SPECIFICATIONS	7
CHAPTER 03	INSTALLATION OF YOUR ICE MAKER	8
CHAPTER 04	OPERATING INSTRUCTIONS	14
CHAPTER 05	CLEANING AND MAINTENANCE	15
CHAPTER 06	TROUBLESHOOTING	25
CHAPTER 07	WARRANTY INFORMATION	27

01. SAFETY WARNINGS

ALWAYS PLUG IN YOUR PRODUCT TO A GROUNDED POWER OUTLET.

- I. YOUR ICE MAKER IS DESIGNED TO OPERATE AT VOLTAGE SHOWN ON TECHNICAL TABLE.
2. RUNNING THE PRODUCT AT A DIFFERENT VOLTAGE MAY CAUSE THE PRODUCT TO BECOME DYSFUNCTIONAL OR EVEN MAY CAUSE FIRE.
3. DO NOT PLACE YOUR ICE MAKER NEXT TO ANY HEAT SOURCE.
4. SET UP YOUR ICE MAKER AT A HUMIDITY-FREE LOCATION AND WITH UN-OBSTRUCTED AIR CIRCULATION AROUND THE UNIT.
5. AFTER THE INSTALLATION IS DONE, DO NOT MOVE YOUR ICE MAKER AND WAIT FOR AT LEAST TWO HOURS BEFORE YOU TURN IT ON.
6. MAKE SURE YOU CLEANED THE INSIDE SURFACE OF YOUR PRODUCT BEFORE FIRSTUSE.
7. DO NOT USE POWER STRIPS OR EXTENSION CORDS TO RUN YOUR PRODUCT.
8. PROTECT THE POWER CORD AGAINST HOT SURFACES.
9. DO NOT LET UN-TRAINED AND/OR UNSUPERVISED CHILDREN YOUNGER THAN 8 YEARS OLD OPERATE YOUR ICE MAKER.
10. THE CLEANING AND MAINTENANCE OF THE DEVICE SHOULD NOT BE MADE BY CHILDREN UNLESS THEY ARE UNDER SUPERVISION.
- II. THE MACHINE MUST NOT BE OPERATED BELOW 10° (CELCIUS).



NOTE

THIS PRODUCT BEARS (AEEE/WEEE) CLASSIFICATION SYMBOLS INDICATING WASTE ELECTRIC AND ELECTRONIC EQUIPMENTS. ACCORDINGLY, THE USER MUST COMPLY WITH THE EUROPEAN DIRECTIVE 2002/96/EC ON RECYCLING FOR THE PURPOSE OF MINIMISING THE IMPACT OF THE WASTE PRODUCT ON THE ENVIRONMENT. IT IS RECOMMENDED TO COMMUNICATE WITH LOCAL AUTHORITIES ABOUT WASTE DISPOSAL.



CAUTION! THIS CONTAINS INFORMATION NECESSARY FOR PREVENTION OF SERIOUS HAZARDS WHICH MAY CAUSE THE PRODUCT TO BECOME DYSFUNCTIONAL, OR MAY CAUSE INJURY OR LOSS OF LIFE AND PROPERTY DURING THE USE OF THE PRODUCT.



WARNING AGAINST ELECTRIC SHOCK.



THIS INDICATES THE EXPLANATORY AND FACILITATING INFORMATION RELATED TO USE OF THE PRODUCT.

02. GENERAL OUTLOOK AND TECHNICAL SPECIFICATIONS



SMALL DIFFERENCES IN COLOR AND OTHER VARIATIONS ARE POSSIBLE FOR DIFFERENT VISUALISATION, IMAGING TECHNOLOGIES OR OTHER TECHNICAL REASONS.

THE MANUFACTURER IS NOT LIABLE FOR THESE DIFFERENCES AND DEVIATIONS. NO RIGHTS CAN BE OBTAINED DUE TO TYPOGRAPHICAL ERRORS, PRODUCT DESCRIPTIONS OR OBVIOUS ERRORS ON THE WEBSITE.

*** ADJUSTABLE LEGS CAN VARY ACCORDING TO PRODUCT MODELS.**

TECHNICAL TABLE

SKU/MODEL	IMF038	IMF037	IMF040	IMF039
REFRIGERANT GAS	R290	R290	R290	R290
PRODUCTION CAPACITY (KG)*	22	26	47	85
STORAGE CAPACITY (KG)	4	8	28	40
ICE CAPACITY PER CYCLE (UNIT)	18	18	44	60
COOLING SYSTEM	AIR	AIR	AIR	AIR
CLIMATE CLASS	T	T	T	T
VOLTAGE	230V-50HZ 115V-60HZ	230V-50HZ 115V-60HZ	230V-50HZ 115V-60HZ	230V-50HZ 115V-60HZ
MAXIMUM POWER	300W	350W	550W	1000W
DAILY ELECTRIC CONSUMPTION	5,1 KW	5,9 KW	12,6 KW	16,4 KW
FUSE **	10 A	10 A	10 A	16 A
PRODUCT WEIGHT (KG)	26	30	45	85
PRODUCT DIMENSION (W*D*H)	355*435*590	390*515*640	500*580*800	738*600*822
PACKING DIMENSION (W*D*H)	415*495*765	450*575*710	555*635*965	800*660*1000

(*) INDICATES THE DAILY ICE MAKING CAPACITY OF THE PRODUCT AT 20 OC AMBIENT AND 10 OC WATER INLET TEMPERATURE.

(**) CHECK THE VALUES OF THE ELECTRICAL NETWORK TO WHICH THE PRODUCT IS CONNECTED.



THE PRESENCE OF PARTICLES IN THE WATER DUE TO QUALITY OF THE WATER SUPPLY AND/OR CONTAMINATION WITH DIRT, INSTALLATION RESIDUE AND SO ON WILL ADVERSELY AFFECT THE OPERATION OF THE ICE MAKER. SUCH CONTAMINATION MAY CAUSE INEFFICIENT OPERATION, NO ICE MAKING, LOUD NOISES, ETC. PROBLEMS WITH THE MACHINE DUE TO PLUMBING AND/OR CALCIFIED WATER ARE NOT COVERED BY THE WARRANTY.

03. INSTALLATION OF YOUR ICE MAKER

SELECTION OF LOCATION FOR YOUR PRODUCT:

- YOUR PRODUCT SHOULD NOT BE IN DIRECT CONTACT WITH OR IN CLOSE PROXIMITY TO ANY HEAT SOURCE.
- YOU SHOULD LEAVE AT LEAST 10 CM OF DISTANCE IF YOU PLACE YOUR ICE MAKER NEXT TO OTHER ELECTRICAL EQUIPMENT (SUCH AS OVENS, COMPUTERS ETC,) THAT ARE CONSIDERED AS HEAT SOURCES.
- IF THE PRODUCT IS TO BE PLACED NEXT TO A WALL, THE DISTANCE BETWEEN THE BACK SURFACE OF THE PRODUCT AND THE WALL SHOULD NOT BE LESS THAN 20 CM (SEE FIGURE-7).
- DO NOT PLACE OBJECTS IN FRONT OF THE VENTILATION FILTER OF YOUR ICE MAKER THAT MIGHT PREVENT AIR CIRCULATION INTO YOUR PRODUCT.
- DO NOT PLACE YOUR PRODUCT OUTDOORS. THIS PRODUCT IS DESIGNED TO BE USED INDOORS.

ELECTRICAL CONNECTION:

- THE VOLTAGE AND FREQUENCY VALUES OF THE MAIN POWER SUPPLY HAVE TO BE THE SAME AS WRITTEN ON THE PRODUCT LABEL. IF YOU ARE IN DOUBT OR NEED ASSISTANCE, PLEASE CONTACT A QUALIFIED ELECTRICIAN.
- MAKE SURE YOUR POWER OUTLET HAS BEEN GROUNDED.
- THE AMPERAGE OF THE CIRCUIT BREAKER TO WHICH THE PRODUCT WILL BE PLUGGED IN SHOULD BE 10A**. (SEE TECHNICAL TABLE / ENTRY FUSE SECTION.)
- DO NOT USE POWER CORDS WITH MULTI-SOCKETS OR EXTENSION CORDS TO OPERATE YOUR PRODUCT.

THE WATER SUPPLY:

- SHOULD BE GOOD FOR HUMAN CONSUMPTION.
- SHOULD HAVE AN OPTIMUM LEVEL OF HARDNESS.
- SHOULD INCLUDE MINIMAL AMOUNT OF CHLORINE.
- THE OPTIMUM WATER FILTERS TO BE USED ON YOUR PRODUCT ARE AVAILABLE AND CAN BE PURCHASED FROM ECATERING.
- WATER TEMPERATURE SHOULD BE BETWEEN 10°C AND 30°C.

INSTALLATION:

1. REMOVE AND DISASSEMBLE ALL PACKAGING MATERIALS OF THE PRODUCT BEFORE INSTALLATION.
2. UNSCREW THE ADJUSTABLE SMALL LEGS UNDER THE PALLET AND THEN REMOVE THE ICE MACHINE FROM THE PALLET



3. REMOVE THE CUSTOMER PACK FROM INSIDE THE ICE MACHINE. IN THE CUSTOMER PACK, THERE IS THE WATER INLET HOSE, WATER OUTLET HOSE, 4 ADJUSTABLE BIG LEGS, ICE CUBE SCOOP, USER MANUAL AND A WATER HARDNESS TESTER.
4. NEXT, FOLLOW THE INSTRUCTIONS ON THE FOLLOWING PAGE TO TEST YOUR WATER SUPPLY HARDNESS AND WHETHER YOU REQUIRE A WATER SOFTENER OR NOT.

MEASURING THE MAINS WATER SUPPLY HARDNESS AND USE OF WATER SOFTENER

0°d	5°d	10°d	15°d	20°d	25°d	German Hardness Degree (d)	French Hardness Degree (f)	English Hardness Degree (e)	Qualification of the Water	Recommended Water Softener
0°f	9°f	18°f	27°f	3°f	45°f					
0°e	6,2°e	12,5°e	18,75°e	25°e	31,25°e					
						0-4	0-7	0-5	Very soft	*
						4-8	7-14	5-10	Soft	**
						8-12	14-22	10-15	Slightly hard	***
						12-18	22-32	15-22	Hard	***
						18-30	32-54	22-35	Very hard	(!)

USING THE TEST PAPER:

- DIP THE TEST PAPER IN TO THE MAINS WATER FOR ONE SECOND.
- TAKE THE PAPER OUT OF THE WATER AND SHAKE.
- COMPARE WHAT YOU SEE ON THE PAPER WITH THE COLOUR SCALE.
- CONSIDER OUR RECOMMENDATIONS ON THE USE OF SOFTENER ACCORDING TO THE HARDNESS TABLE.

THE HARDNESS IS DIRECTLY PROPORTIONAL TO THE AMOUNT OF LIME THE WATER CONTAINS. AS THE HARDNESS INCREASES, THE AMOUNT OF LIME INCREASES. THE LIME IN THE WATER CAN AFFECT THE PROPER FUNCTIONING OF YOUR ICE MAKER. IN CASE OF NON-USAGE OF A SOFTENER, IT CAN CAUSE FREQUENT MAINTENANCE ISSUES AND LACK OF FUNCTION THAT MAY REQUIRE REPAIRS OUTSIDE OF THE WARRANTY, EVEN WITH WATER THAT IS CONSIDERED SOFT.

- * USE OF WATER SOFTENER IS NOT REQUIRED.
- ** USE OF WATER SOFTENER IS RECOMMENDED FOR THE LIFE OF YOUR ICE MAKER.
- *** WATER SOFTENER HAS TO BE USED (!) SHOULD NOT BE OPERATED WITHOUT ONE.

5. SCREW ON THE ADJUSTABLE LEGS.



6. ENSURE THAT THE APPLIANCE IS STANDING PERFECTLY LEVEL

7. THEN CLEAN THE INNER CABINET WITH WARM WATER AND A SOFT CLOTH BEFORE USING THE ICE MAKER. THEN DRY WITH A SOFT, COTTON CLOTH.

8. AFTER PLACING THE ICE MAKER AT THE INSTALLATION POINT, WAIT 2 HOURS BEFORE INSTALLING AND OPERATING TO GET THE COOLING SYSTEM PRESSURE STABILIZED.

9. ON THE BACK OF THE MACHINE REMOVE THE RUBBER CAP FROM THE WATER INLET PIPE.

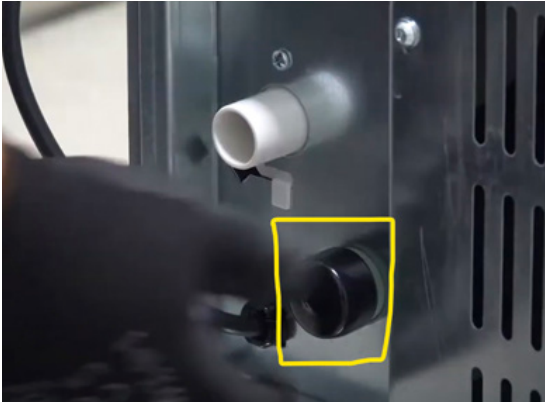

10. THEN SCREW ON THE 3/4" WATER INLET HOSE INCLUDED IN THE PACK AND ENSURE IT IS FIRMLY TIGHTENED.



Firmly tighten the included 3/4" water inlet hose



(PLEASE NOTE, THE COLD WATER INLET PRESSURE MUST NOT EXCEED THE OPERATING WATER PRESSURE (5 BAR) INDICATED ON THE TECHNICAL DATA SHEET. IF THE LINE PRESSURE IS HIGHER THAN 5 BAR, A PRESSURE REDUCER MUST BE INSTALLED.)

11. NEXT, FIX ON THE WATER DRAIN HOSE TO THE ICE MACHINE AND ENSURE IT SLOPES DOWNWARDS AT LEAST 15%



Fix water drain hose, assure it slopes downwards at least 15%

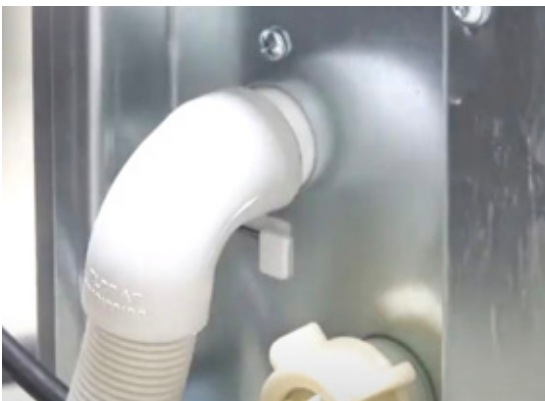

12. THEN PUSH THE DRAIN HOSE IN YOUR WATER OUTLET DRAIN.



13. NEXT, ATTACHED THE OTHER END OF THE WATER INLET HOSE TO YOUR WATER INLET PIPE, AND THEN TURN ON YOUR WATER VALVE.



14. REMOVE THE PLASTIC FLAP CURTAINS BY LIFTING THEM UP OUT OF THE SLOT THEY SIT IN



15. REMOVE THE ICE SLIDE DECK BY LIFTING IT UP AND OUT OF ITS POSITION.



16. ENSURE THE PLASTIC WATER LEVEL DRAIN AND THE SPRAYERS ARE SITTING PERFECTLY AND LEVEL IN THEIR POSITION.

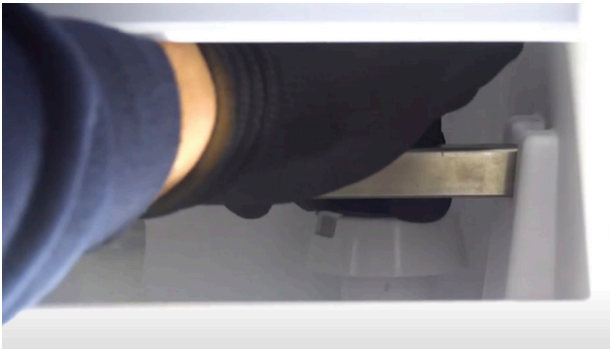

17. RE-INSERT THE PLASTIC SLIDE DECK INTO THE WATER BASIN AND ENSURE IT IS BEHIND THE FRONT PLASTIC BIT/LIP OF THE WATER BASIN LIKE THE PICTURE BELOW:



18. PLUG IN THE ICE MACHINE TO YOUR SOCKET AND TURN ON THE ICE MACHINE.



- PROTECT YOUR DEVICE AGAINST FACTORS THAT MAY DAMAGE THE PACKAGE AND THE DEVICE (MOISTURE, WATER, IMPACT, CHEMICALS, ETC.).
- ONLY A QUALIFIED ENGINEER SHOULD DISASSEMBLE THE DEVICE. NEVER INTERFERE WITH THE INTERNAL PARTS AND ELEMENTS OF THE ICE-MAKER.
- THE DEVICE MUST BE COMMISSIONED BY A CERTIFIED ENGINEER.
- FAILURE TO COMPLY WITH THE ABOVE CONDITIONS WILL VOID YOUR PRODUCT WARRANTY.
- DO NOT LEAVE PACKAGING MATERIALS (PLASTIC BAGS, NYLON, ETC.) WITHIN THE REACH OF CHILDREN.
- THE SUPPLIER RESERVES THE RIGHT TO CHANGE THE INFORMATION IN THIS MANUAL. THEREFORE; THIS BOOKLET DOES NOT CONSTITUTE A COMMITMENT TO SPECIFICATIONS.

04. OPERATING INSTRUCTIONS

OPERATING THE ICE MAKER:

AFTER INSTALLING YOUR ICE MAKER FOLLOWING THE INSTRUCTIONS ABOVE AND MAKING ALL NECESSARY CONNECTIONS;

1. MAKE SURE THAT THE POWER OUTLET YOU ARE USING FOR YOUR ICE-MAKER IS LIVE AND HAS POWER.
2. TURN ON THE WATER.
3. SET THE ON-OFF BUTTON AT THE FRONT OF YOUR PRODUCT TO THE ON POSITION.(WHEN YOU SET IT TO THE ON POSITION, THE POWER LIGHT ON THE BUTTON WILL TURN ON.)
4. THE PRODUCT WILL AUTOMATICALLY GO INTO A DELAY-TIME MODE FOR 5 MINUTE AFTER IT IS TURNED ON.
5. AT THE END OF THE DELAY-TIME MODE, THE PRODUCT WILL START GETTING WATER AND MAKING ICE.
6. YOUR PRODUCT WILL COMPLETE THE ICE-MAKING CYCLE AFTER A CERTAIN TIME, DEPENDING ON THE AMBIENT AND WATER TEMPERATURE.

NOTE: IN ORDER TO ALLOW YOUR PRODUCT TO MAKE ICE IN THE OPTIMUM DIMPLE SIZE AND TIME, YOU NEED TO WAIT FOR AT LEAST 2 HOURS AFTER THE INSTALLATION, BEFORE TURNING ON THE MACHINE.

SHUTTING OFF THE ICE MAKER:

1. SET THE POWER BUTTON AT THE FRONT OF YOUR ICE MAKER TO “OFF” POSITION.
2. UNPLUG THE PRODUCT IF YOU ARE NOT GOING TO USE THE ICE-MAKER FOR A LONG TIME.
3. TURN OFF THE WATER.

THERE ARE SOME MALFUNCTION AND WARNING SIGNALS DEFINED FOR THE RED LIGHT ON THE POWER BUTTON OF THE PRODUCT AS DETAILED IN THE CHART BELOW:

Function Mode	On	Off
Cleaning	3 sec	1 sec
Fault	2 sec	2 sec
Ice Bin Full	1 sec	1 sec

05. CLEANING AND MAINTENANCE

SAFETY RULES MUST BE OBSERVED BEFORE CLEANING YOUR ICE MAKER:

1. UNLESS OTHERWISE SPECIFIED, TURN OFF AND UNPLUG THE UNIT BEFORE STARTING TO CLEAN THE ICE MAKER.
2. THE OUTER CABINET OF THE PRODUCT SHOULD ONLY BE CLEANED BY WIPING WITH A DAMP CLOTH. DO NOT SPRAY THE UNIT WITH WATER OR ANY OTHER CLEANING SOLVENT. THIS CAUSES UNDESIRED ELECTRICAL FAILURES AND JEOPARDIZES THE SAFETY OF THE USER.
3. ALWAYS WEAR PROTECTIVE GLOVES AND SIMILAR PROTECTIVE EQUIPMENT DURING CLEANING.
4. NEVER USE CLEANING AGENTS AND CHEMICALS WHICH MAY CAUSE CUTTING, PIERCING AND CORROSION TO YOUR PRODUCT. YOUR ICE MAKER WILL BE OUT OF WARRANTY IF THESE TYPE OF CHEMICALS ARE USED FOR CLEANING
5. WE RECOMMEND USING THE CLEANING AGENT “ESSENTIAL VALUES ICE MACHINE CLEANER” - SEE PICTURE BELOW:

EXTERIOR CLEANING OF THE ICE MAKER:

THE EXTERIOR OF YOUR ICE-MAKER IS MADE OF STAINLESS STEEL. WIPE THE EXTERIOR SURFACES WITH A DAMP CLOTH OR A SPONGE AND THEN WIPE IT WITH A DRY, CLEAN CLOTH.

CLEANING OF THE WATER FILTER:

1. TURN OFF THE ICE MACHINE BY PRESSING THE BUTTON WITH THE GREEN BUTTON AND DISCONNECT FROM THE MAIN POWER SUPPLY BY PULLING THE PLUG OUT.

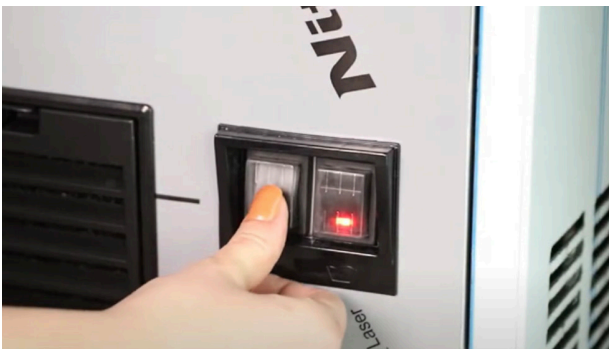

2. DISCONNECT THE WATER CONNECTION OF YOUR ICE MACHINE.
3. REMOVE THE WATER FILTER, BY PULLING IT OFF THE PIPE. THE WATER INLET FILTER SHOULD BE CLEANED REGULARLY, OTHERWISE THE FILTER WILL GET CLOGGED AND THE ICE MACHINE WILL NOT PRODUCE ICE.



4. ONCE YOU HAVE REMOVED THE WATER FILTER, THEN RINSE IT THOROUGHLY WITH WATER.



5. THEN, REFIT THE WATER FILTER INTO THE ICE MACHINE, BY PUSHING IT ONTO THE PIPE.



6. FINALLY, RECONNECT THE WATER CONNECTION TO YOUR ICE MACHINE AND RECONNECT TO THE MAINS POWER SUPPLY AND TURN ON YOUR ICE MACHINE.

WE RECOMMEND CLEANING THE WATER FILTER EVERY MONTH AND REPLACING THE WATER FILTER EVERY 6 MONTHS. YOU CAN PURCHASE THE FILTER FROM ECATERING – 0333 358 3678.

CLEANING OF THE ICE MACHINE:

- 1. MAKE SURE THE WATER AND ELECTRICAL CONNECTIONS OF THE PRODUCT ARE IN COMPLIANCE WITH THE CLEANING INSTRUCTIONS ABOVE.**
- 2. REMOVE ALL THE ICE FROM THE STORAGE BIN**



3. REMOVE THE TOP OF THE ICE MACHINE BY REMOVING THE SCREWS OF THE TOP PANEL AT THE REAR OF THE ICE MACHINE

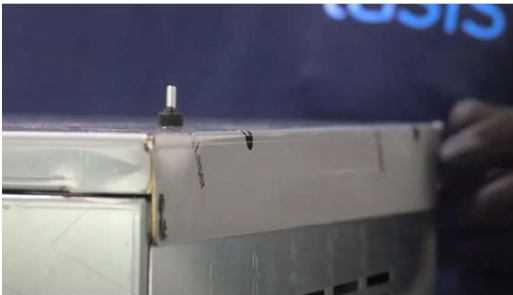
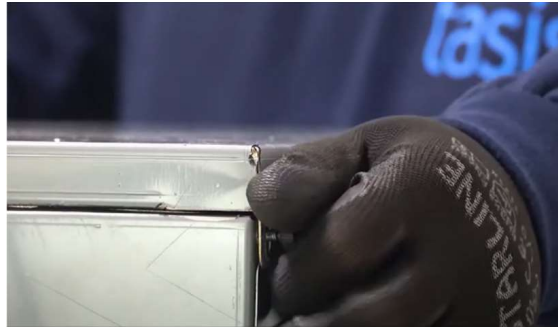

4. REMOVE THE TOP PANEL BY SLIDING IT BACK AND THEN LIFTING IT UP

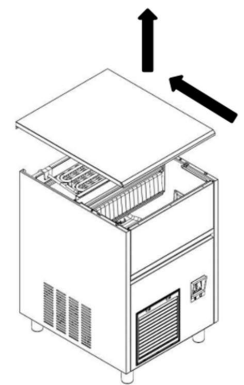

5. THEN REMOVE THE DOOR BY OPENING IT AND THEN LIFTING THE WHITE RUNNERS POSITIONED EACH SIDE OF THE DOOR OUT OF THE SLOT AT THE TOP OF THE ICE MACHINE LIKE THE BELOW.



6. REMOVE THE PLASTIC FLAP CURTAINS BY LIFTING THEM UP OUT OF THE SLOT THEY SIT IN



7. REMOVE THE ICE SLIDE DECK BY LIFTING IT UP AND OUT OF ITS POSITION.



8. THEN POUR A MIX OF WATER AND ICE MAKER CLEANING SOLUTION INTO THE BASIN. PLEASE FOLLOW THE INSTRUCTIONS ON YOUR CLEANING SOLUTION AS TO THE RATIO OF WATER AND CLEANING SOLUTION. WE RECOMMEND USING ESSENTIAL VALUES ICE MACHINE CLEANER WHICH CAN BE PURCHASED ONLINE. (SEE PICTURE OF THE CLEANING SOLUTION BELOW)



9. REFIT THE PLASTIC FLAP CURTAINS



10. SWITCH ON THE APPLIANCE



II. WITHIN 30 SECONDS OF TURNING ON THE POWER, YOU MUST PRESS AND HOLD THE CLEANING BUTTON FOR 9 SECONDS.



12. THE CLEANING PROCESS WILL CONTINUE FOR 10 MINUTES, AND THE RED LIGHT ON THE CLEANING BUTTON WILL BE ON FOR 3 SECONDS AND THEN OFF FOR 1 SECOND, ETC

13. WHILST THE CLEANING PROCESS IS TAKING PLACE, REMOVE THE TOP PLASTIC SHEET ABOVE THE EVAPORATOR/COOLING PIPES.



14. THEN POUR A MIX OF WATER AND ICE MAKER CLEANING SOLUTION ONTO THE EVAPORATOR/COOLING PIPES. PLEASE FOLLOW THE INSTRUCTIONS ON YOUR CLEANING SOLUTION AS TO THE RATIO OF WATER AND CLEANING SOLUTION. WE RECOMMEND USING ESSENTIAL VALUES ICE MACHINE CLEANER.

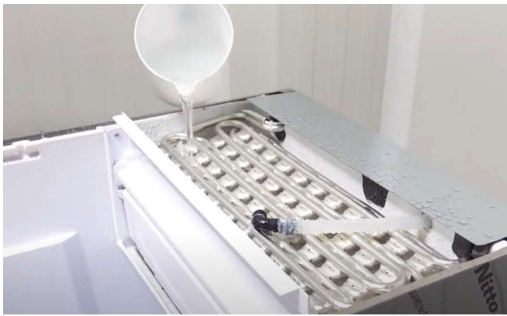

15. THEN REFIT THE PLASTIC TOP COVER ABOVE THE EVAPORATOR/COOLING PIPES.



16. WHEN THE CLEANING CYCLE HAS FINISHED (AFTER 10 MINS), THE RED LIGHT ON THE CLEANING BUTTON WILL TURN ON.



17. TURN ON THE ICE MACHINE TO END THE CLEANING CYCLE.

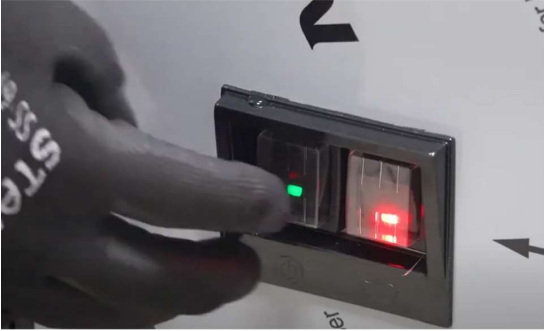

18. THEN REMOVE THE PLASTIC FLAP CURTAINS BY LIFTING THEM UP AND OUT OF THE SLOT THEY SIT IN.



19. REMOVE THE SPRAYERS BAR BY LIFTING IT UP AND OUT OF THE SLOT IT SITS IN.



20. THEN, REMOVE THE PLASTIC WATER LEVEL DRAIN BY LIFTING IT UP AND OUT OF THE WATER BASIN, AND THEN LET THE WATER DRAIN OUT OF THE WATER BASIN.



21. NEXT, REMOVE THE REMOVE THE TOP PLASTIC SHEET ABOVE THE EVAPORATOR/COOLING PIPES.



22. POUR PLENTY OF WATER OVER THE EVAPORATOR/COOLING PIPES.

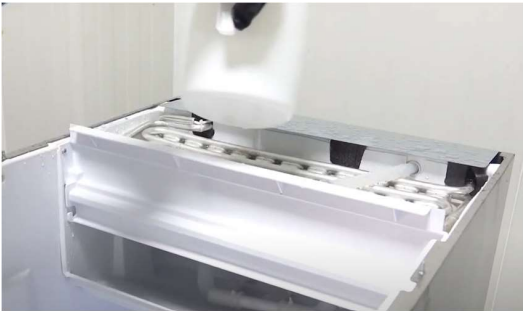

23. ALSO POUR PLENTY OF WATER AROUND THE STORAGE BIN, AND RINSE THE PLASTIC WATER LEVEL DRAIN, WATER BASIN, SPRAYERS, PLASTIC SLIDE GRATE AND PLASTIC FLAP CURTAINS WITH WATER.



24. THEN DRY ALL THE COMPONENTS AND THE ICE MACHINE USING A DRY CLOTH.



25. THEN REFIT THE PLASTIC WATER LEVEL DRAIN BY PUSHING IT DOWN INTO THE HOLE IN THE WATER LEVEL BASIN.



26. REFIT THE SPRAYER BAR INTO THE SLOTS ON THE SIDE OF THE WATER BASIN AND PUSH DOWN TO SLOT IN AND ENSURE IT IS LEVEL.



27. RE-INSERT THE PLASTIC SLIDE DECK INTO THE WATER BASIN AND ENSURE IT IS BEHIND THE FRONT PLASTIC BIT/LIP OF THE WATER BASIN LIKE THE PICTURE BELOW:



28. RE-INSERT THE PLASTIC FLAP CURTAINS BACK IN THE SLOT.



29. REFIT THE DOOR INTO THE SLOTS EITHER SIDE OF THE ICE MACHINE AT THE TOP, BY INSERTING THE WHITE PLASTIC PEGS AT THE BOTTOM OF THE DOOR FIRST AND THEN SLIDING IT ALONG TO THEN ALLOW YOU TO INSERT THE WHITE PLASTIC PEGS AT THE TOP OF THE DOOR. PUSH THE WHITE PLASTIC PEGS IN TO ALLOW YOU TO INSERT THEM INTO THE RAIL, AND THEN CLOSE THE DOOR.



30. THEN REFIT THE PLASTIC TOP COVER ABOVE THE EVAPORATOR/COOLING PIPES.



31. ALSO REFIT THE LID OF THE TOP OF THE ICE MACHINE AND THEN SLIDE FORWARDS TO ENSURE IT LOCKS IN CORRECTLY, AND PUT THE 2 SCREWS BACK IN AT THE REAR OF THE ICE MACHINE.

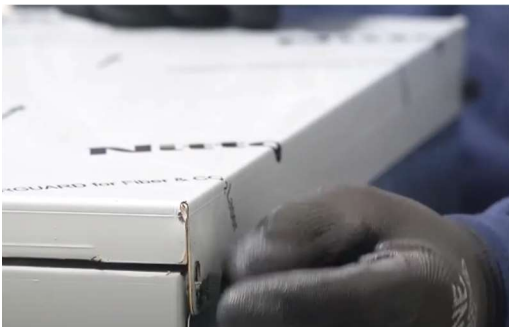

32. FINALLY TURN ON THE ICE MACHINE AND DISPOSE OF THE FIRST 4 CYCLES OF ICE CUBES THAT IT MAKES TO AVOID ANY TASTE IN THE ICE OF THE CLEANING SOLUTION.



06. TROUBLESHOOTING

Malfunction	Probable Reason	Solution
Ice Maker does not work	Power button is Off.	Set the power button to the "On" position.
	The power connection is faulty.	Get the power connection checked by a qualified electrician.
	The Ice Maker is in protection mode.	Check the place selection instructions of the ice maker. Ice Maker does not receive adequate amount of air.
	No power in the outlet.	Check the fuse connected to the outlet.
The compressor stops shortly after it starts working	Ambient temperature is very high	Check the place selection instructions of the ice maker. Ice Maker does not receive adequate amount of air. Clean the ventilation filter.
	Grid voltage is low	Get the power connection checked by a qualified electrician.
Ice Set is cooled but the water inside the water pool is insufficient	Water valve is faulty	Contact the nearest Authorised Service.
	Water supply pressure is low	Make sure that the water supply pressure is greater than 1 Bar.
	Water level drain plastic group seeps	Place the water level plastic group to its slot tightly.
Ices are not transparent	Water nozzle is blocked	Water nozzle sprayer should be checked. The blocked nozzles should be cleaned.
	Water pool is dirty	Clean the Ice Maker by following the cleaning instructions.
	Pressure of the water pump is low	Contact the nearest Authorised Service.
	The water is blurry / dirty / chlorinated	Use a water filter.
Ices are much smaller than they should be.	Water is insufficient	Place the water level plastic group to its slot tightly.
	Cooling system is faulty	Check the water main connection for the water leakage. Contact the nearest Authorised Service.
Ices are much bigger than they should be.	Time setting is incorrect	Set the time on the electronic card to a lower value.
	Sensor is faulty	Contact the nearest Authorised Service.
The quantity of the ice is insufficient	Gas leakage in the defrost solenoid	Contact the nearest Authorised Service.
	Water valve is faulty	Contact the nearest Authorised Service.
Device does not stop when the ice bin is full	Sensor is faulty	Contact the nearest Authorised Service.



07. WARRANTY INFORMATION

THIS WARRANTY PROVIDED BY OUR COMPANY DOES NOT COVER THE REPAIR OF DEFECTS CAUSED BY UNUSUAL USE OF THE ICE MAKER, AND THE FOLLOWING ITEMS ARE EXCLUDED FROM THE WARRANTY.

MALFUNCTIONS AND DAMAGES CAUSED BY THE OPERATOR DURING USE.

MALFUNCTIONS AND DAMAGES THAT OCCURRED DURING SHIPMENT OR DURING LOADING OR UNLOADING AND DURING DELIVERY TO THE END-USER,

MALFUNCTIONS AND DAMAGES THAT OCCURRED DUE TO LOW OR HIGH VOLTAGE, USAGE CONTRARY TO THE VOLTAGE WRITTEN ON THE LABEL OF THE PRODUCT AND THE ELECTRICAL INSTALLATION.

MALFUNCTIONS AND DAMAGES THAT OCCURRED AFTER ANY FIRE OR LIGHTNING DURING USE, MALFUNCTIONS RESULTING FROM USE OF THE PRODUCT CONTRARY TO THE WARNINGS AND METHODS SPECIFIED IN THE USER MANUAL,

THE REPAIRING OF THE ABOVE-MENTIONED MALFUNCTIONS SHALL NOT BE INCLUDED IN THE SCOPE OF THE WARRANTY, THE REPAIR SHALL BE CHARGED.

THE WARRANTY IS VALID FOR THE PERIOD MENTIONED IN THE WARRANTY CERTIFICATE AND ONLY FOR THE MALFUNCTIONS THAT OCCURRED IN THE PRODUCT; NO OTHER CLAIMS, FOR A REFUND, REPAIR OR REPLACEMENT SHALL BE DONE. IN THE CASE THAT ANY DESTRUCTION/FALSIFICATION OF THE ORIGINAL SERIAL NUMBER RECORDED ON THE WARRANTY CERTIFICATE AND ON THE PRODUCT IS FOUND, THE PRODUCT SHALL BE OUT OF WARRANTY. AS FOR THE REPAIRS WITHIN THE SCOPE OF THE WARRANTY, ONLY THE SERVICES SPECIFIED IN THE WARRANTY CERTIFICATE OR ON OUR WEBSITE ARE AUTHORISED.



CONTENDER COMMERCIAL ICE MAKER 22KG · SKU: IMF038

CONTENDER COMMERCIAL ICE MAKER 26KG · SKU: IMF037

CONTENDER COMMERCIAL ICE MAKER 47KG · SKU: IMF040

CONTENDER COMMERCIAL ICE MAKER 85KG · SKU: IMF039



STEP UP TO THE PLATE